

CONDENSATE RETURN UNIT

DIMENSIONS

8 GALLON SIMPLEX
STEEL OR STAINLESS STEEL RECEIVER

3/4" DISCHARGE

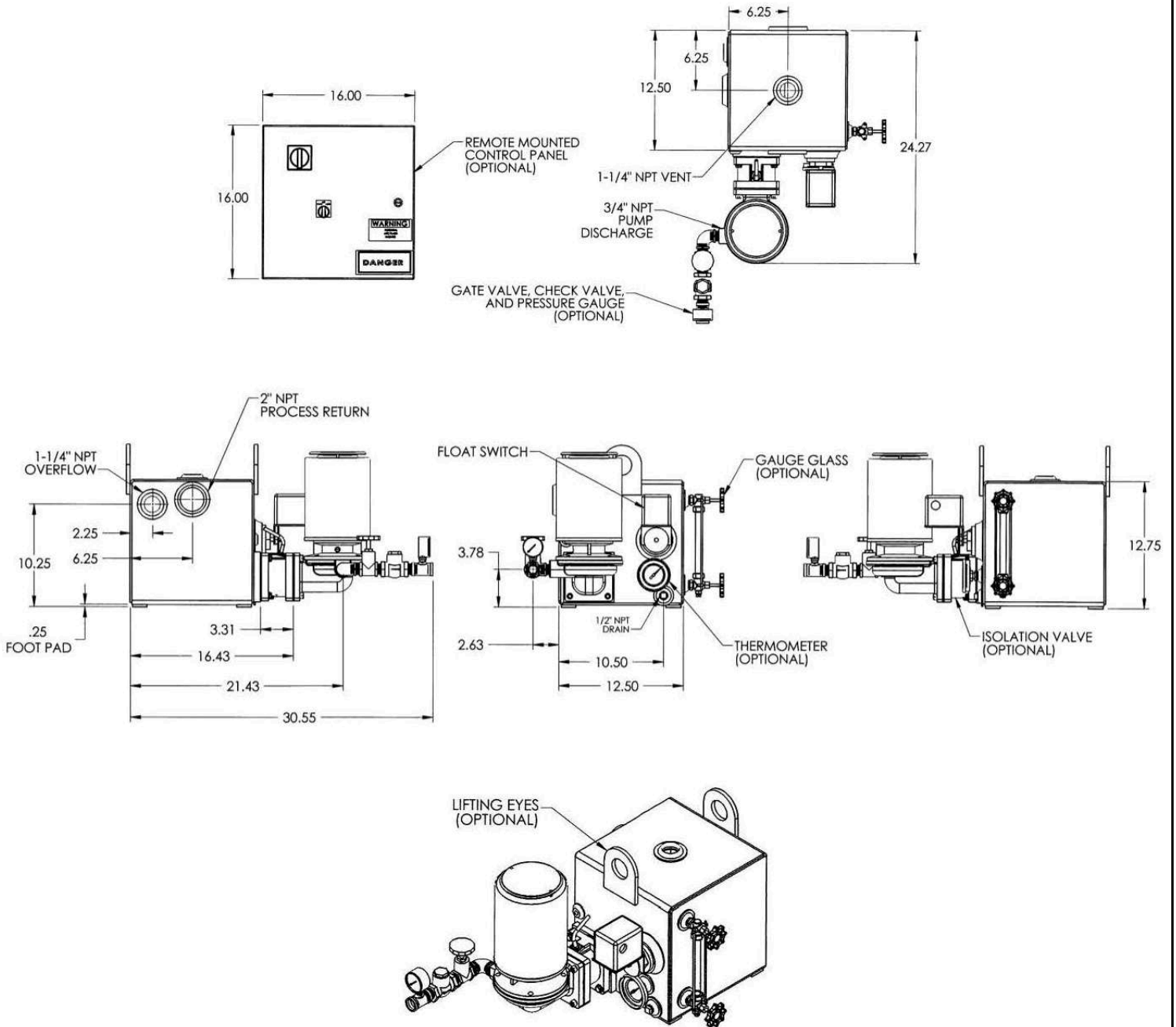

SPECIFY WITH CONFIDENCE, SPECIFY PENN PUMP SYSTEMS

CONDENSATE RETURN UNIT

DIMENSIONS

15 GALLON SIMPLEX
STEEL OR STAINLESS STEEL RECEIVER

3/4" DISCHARGE

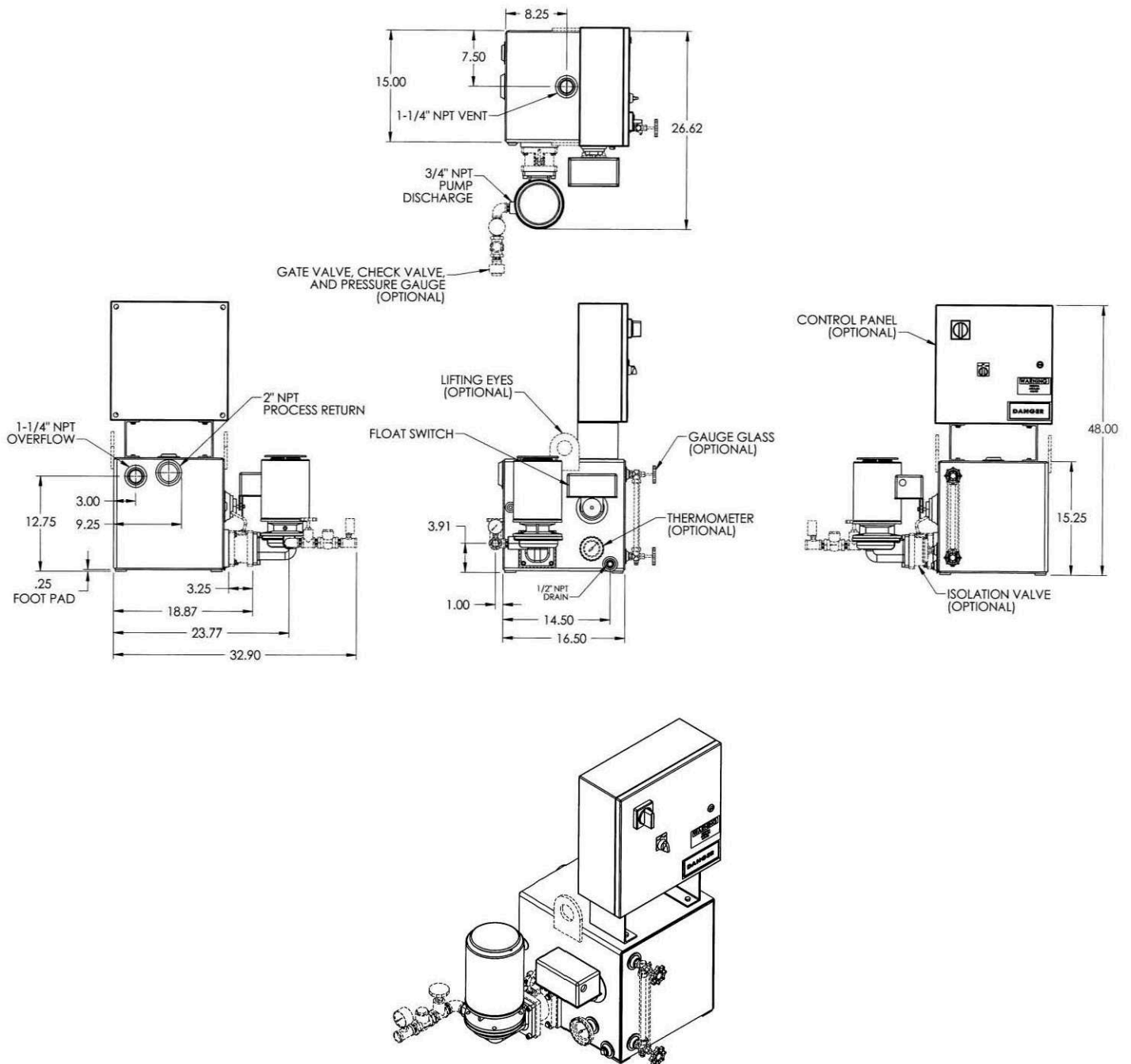

SPECIFY WITH CONFIDENCE, SPECIFY PENN PUMP SYSTEMS

CONDENSATE RETURN UNIT

DIMENSIONS

15 GALLON DUPLEX
STEEL OR STAINLESS STEEL RECEIVER

$\frac{3}{4}$ " DISCHARGE

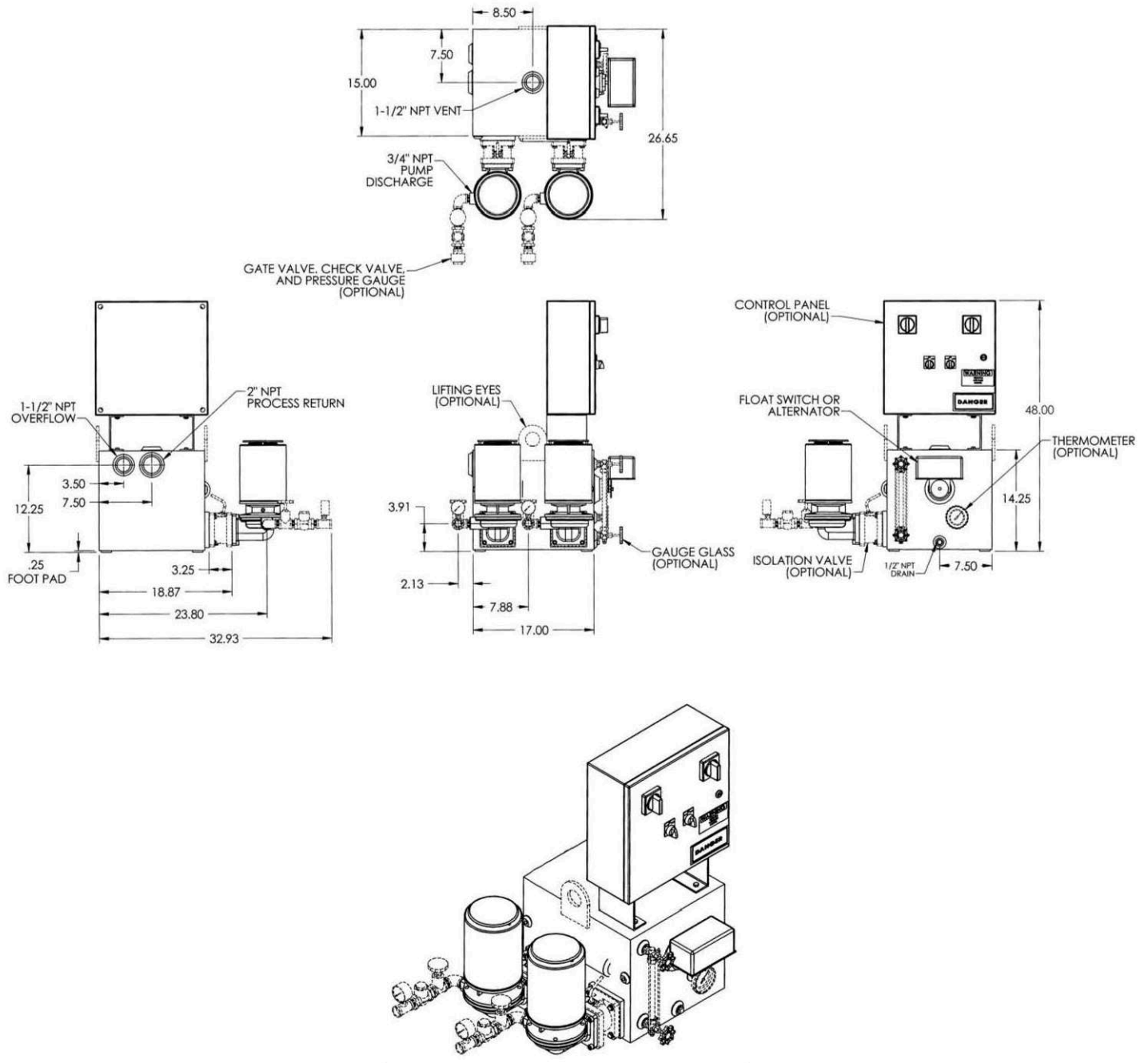

SPECIFY WITH CONFIDENCE, SPECIFY PENN PUMP SYSTEMS

CONDENSATE RETURN UNIT

DIMENSIONS

**30 GALLON SIMPLEX
STEEL OR STAINLESS STEEL RECEIVER**

3/4" DISCHARGE

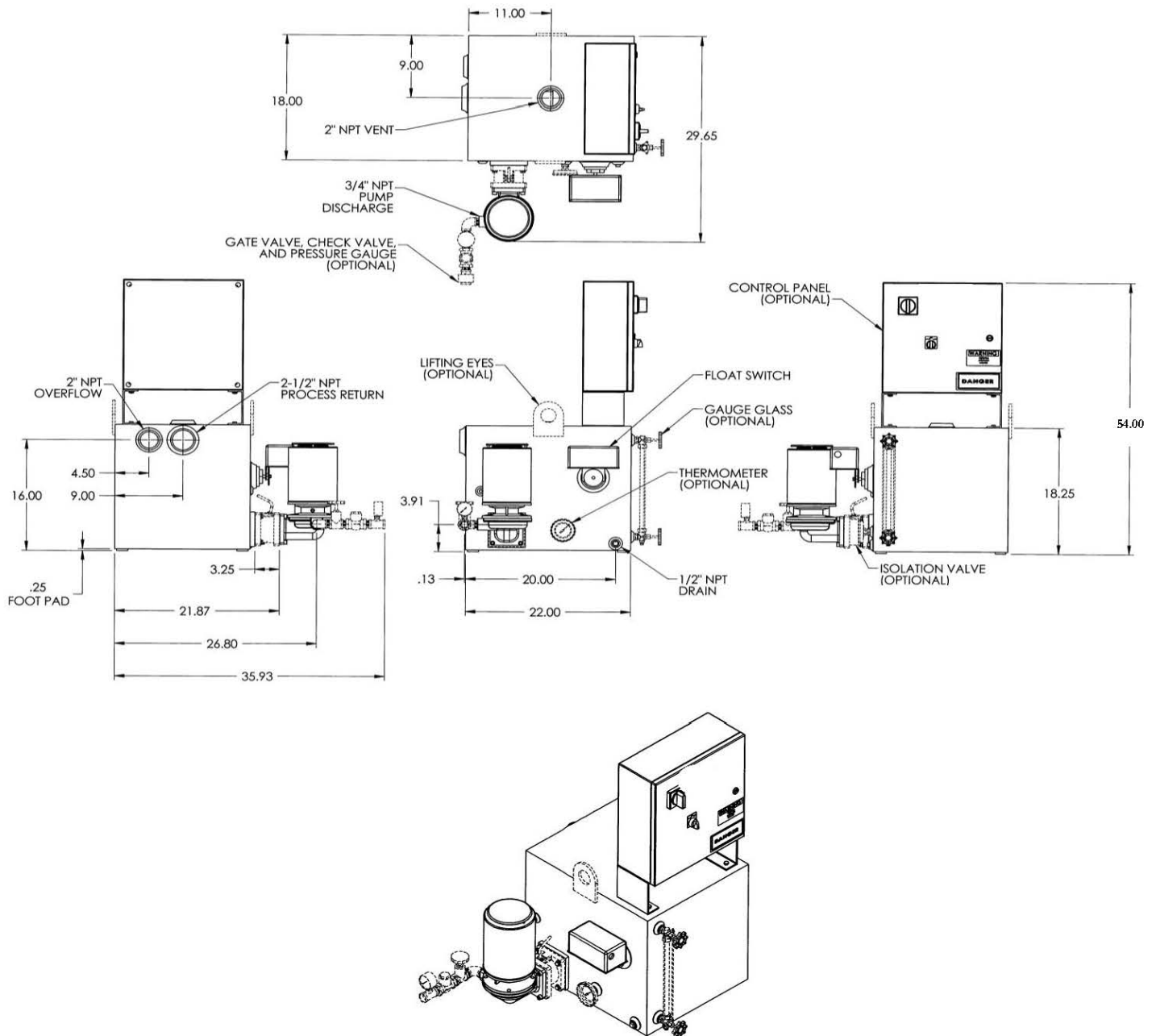

SPECIFY WITH CONFIDENCE, SPECIFY PENN PUMP SYSTEMS

CONDENSATE RETURN UNIT

DIMENSIONS

30 GALLON DUPLEX
STEEL OR STAINLESS STEEL RECEIVER

$\frac{3}{4}$ " DISCHARGE

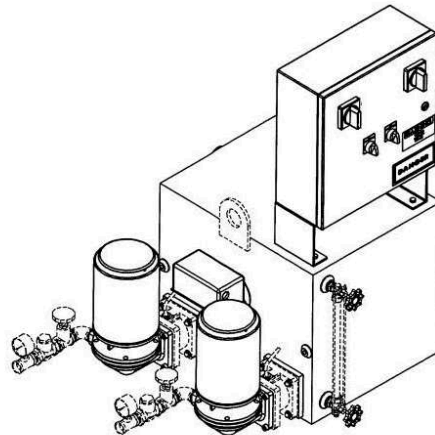
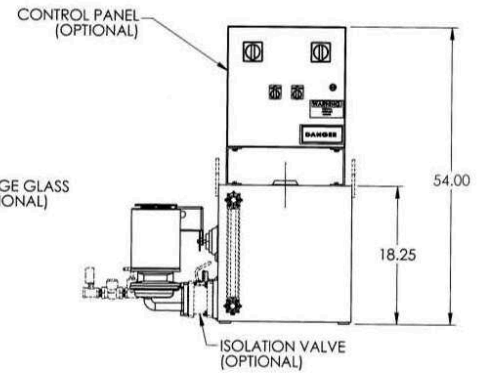
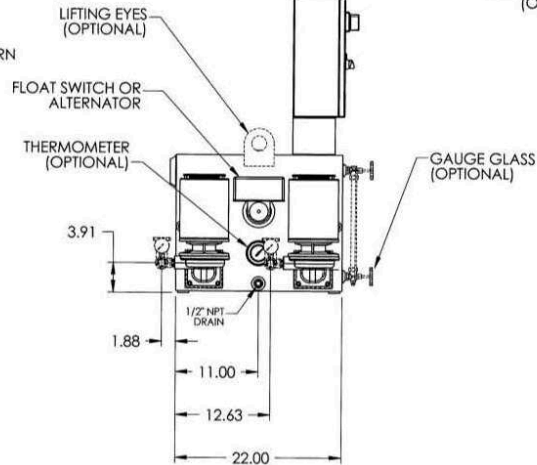
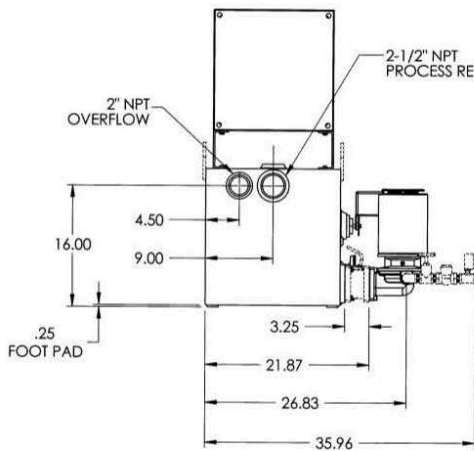
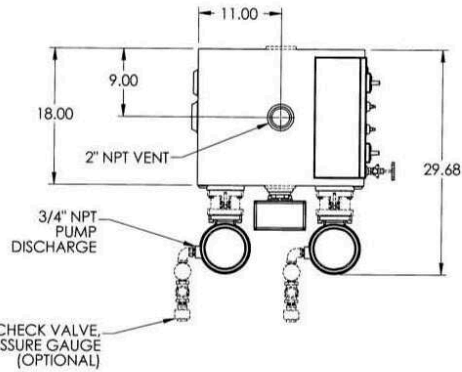

SPECIFY WITH CONFIDENCE, SPECIFY PENN PUMP SYSTEMS

CONDENSATE RETURN UNIT

DIMENSIONS

45 GALLON SIMPLEX/DUPLEX
STEEL OR STAINLESS STEEL RECEIVER

3/4" DISCHARGE

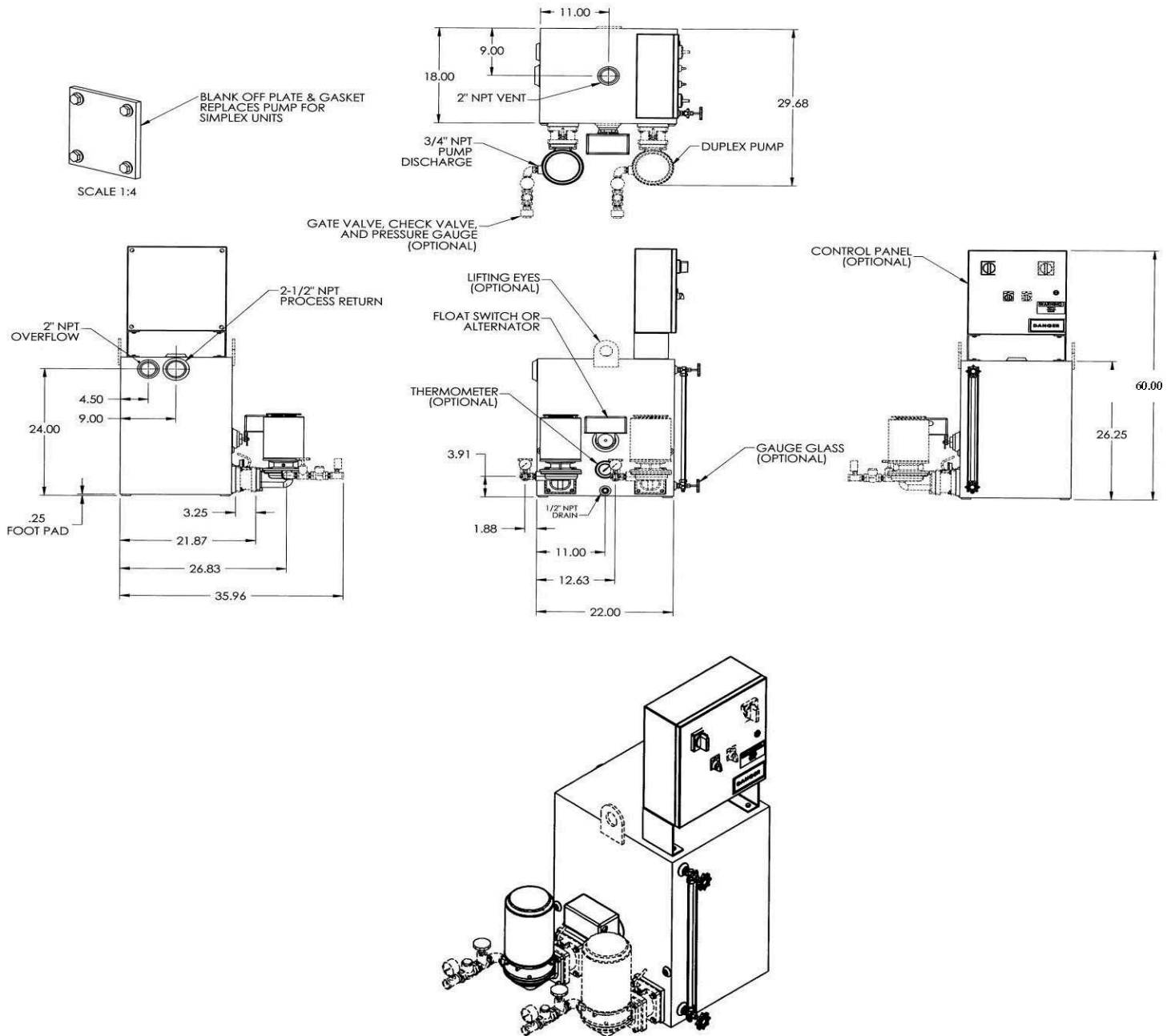

SPECIFY WITH CONFIDENCE, SPECIFY PENN PUMP SYSTEMS

CONDENSATE RETURN UNIT

DIMENSIONS

60 GALLON SIMPLEX/DUPLEX
STEEL OR STAINLESS STEEL RECEIVER

3/4" DISCHARGE

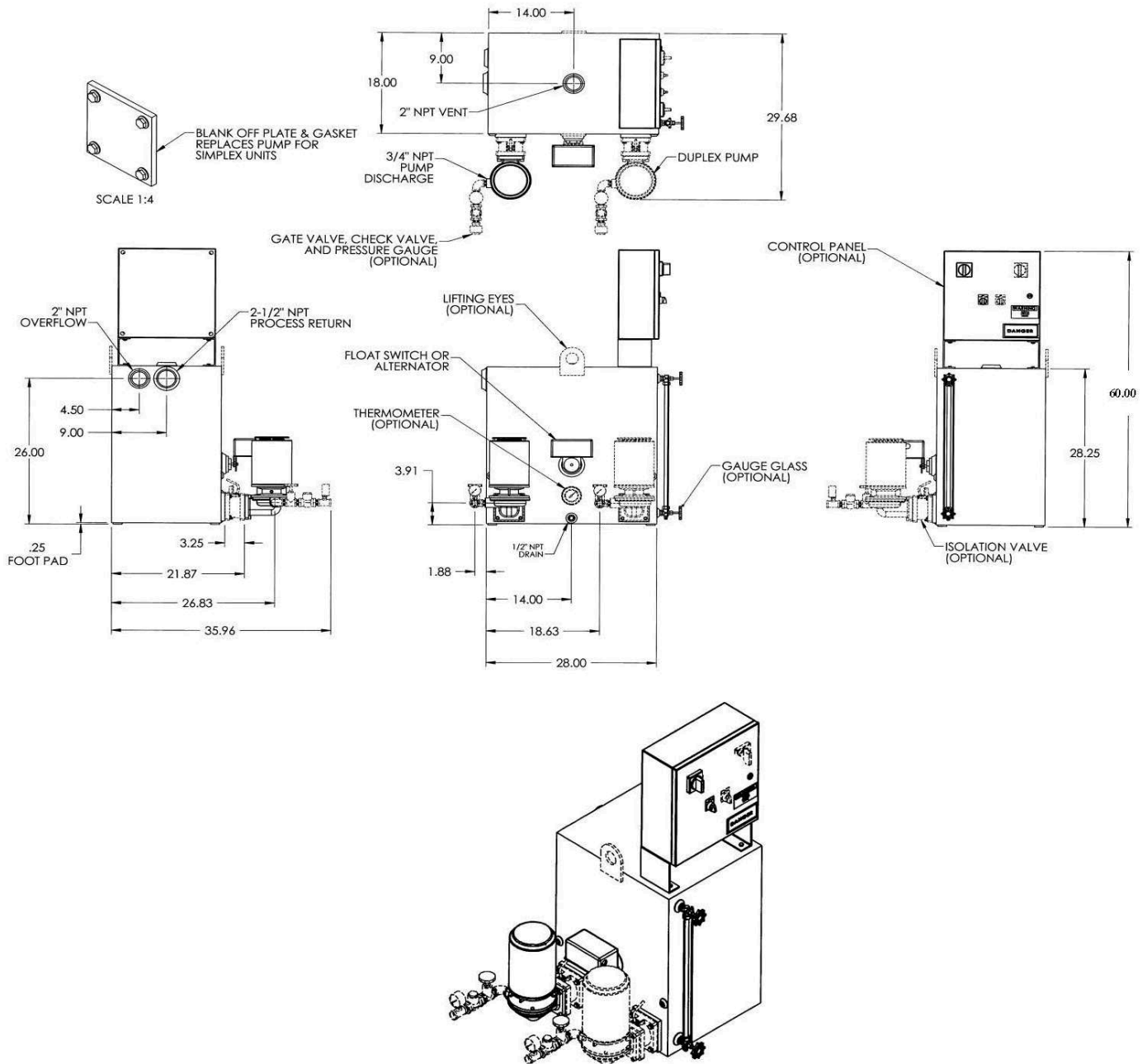

SPECIFY WITH CONFIDENCE, SPECIFY PENN PUMP SYSTEMS

CONDENSATE RETURN UNIT

DIMENSIONS

**95 GALLON SIMPLEX/DUPLEX
STEEL OR STAINLESS STEEL RECEIVER
3/4" DISCHARGE**

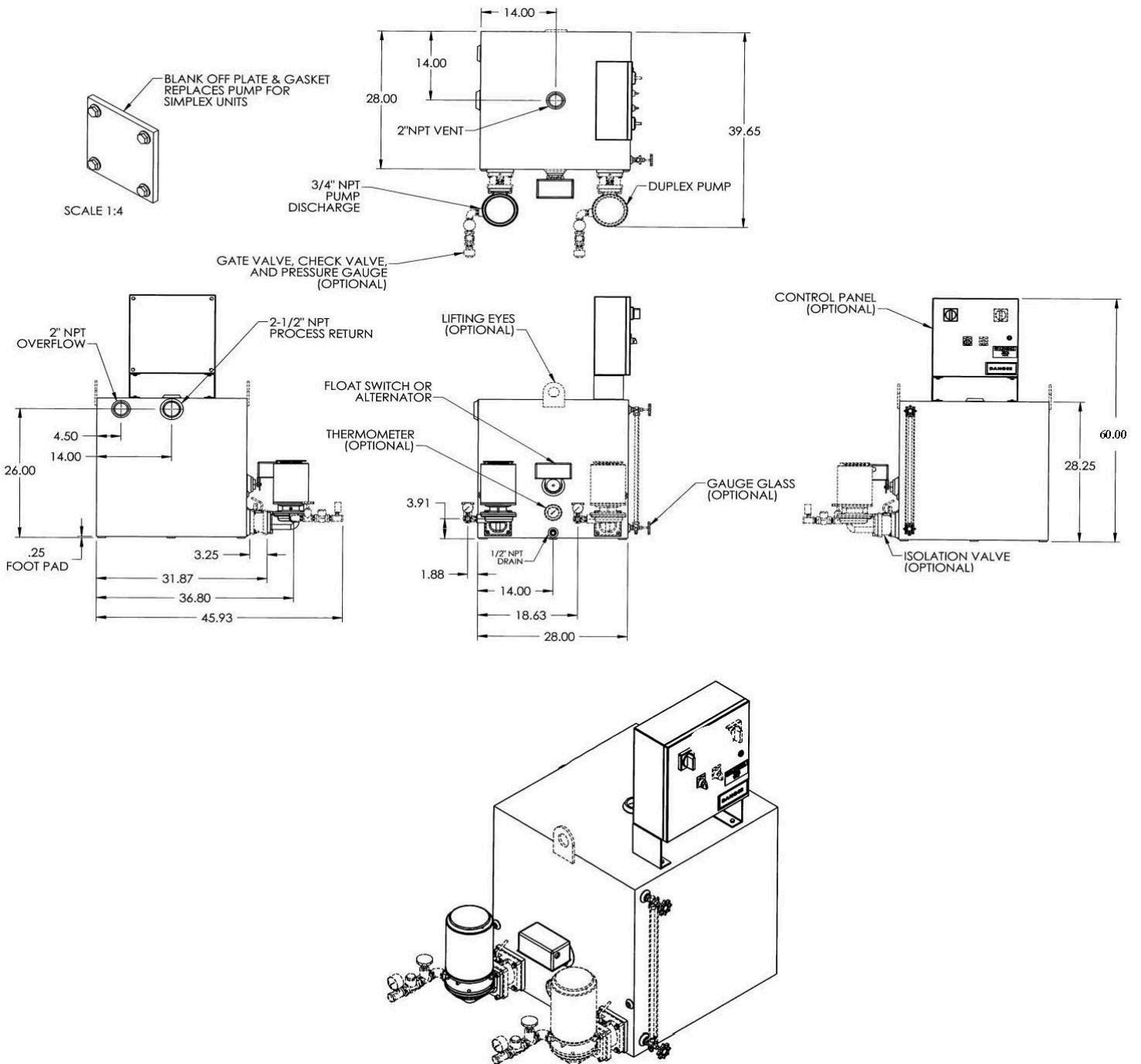

SPECIFY WITH CONFIDENCE, SPECIFY PENN PUMP SYSTEMS

CONDENSATE RETURN UNIT

DIMENSIONS

**120 GALLON SIMPLEX/DUPLEX
STEEL OR STAINLESS STEEL RECEIVER
3/4" DISCHARGE**

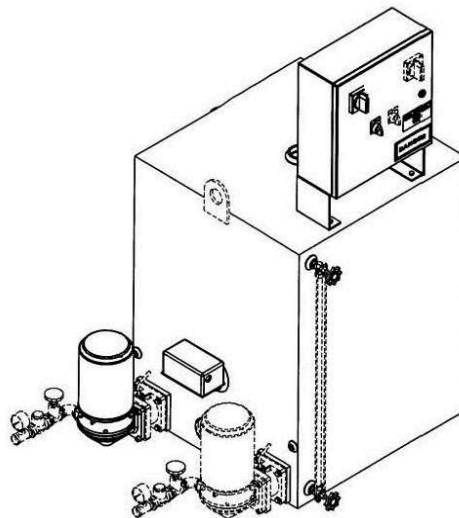
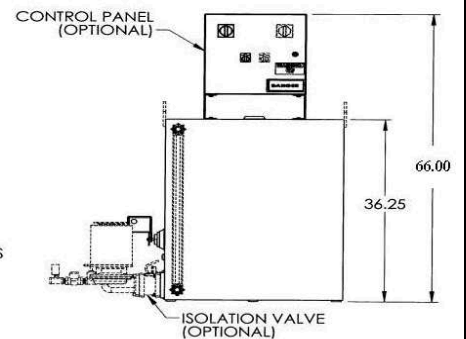
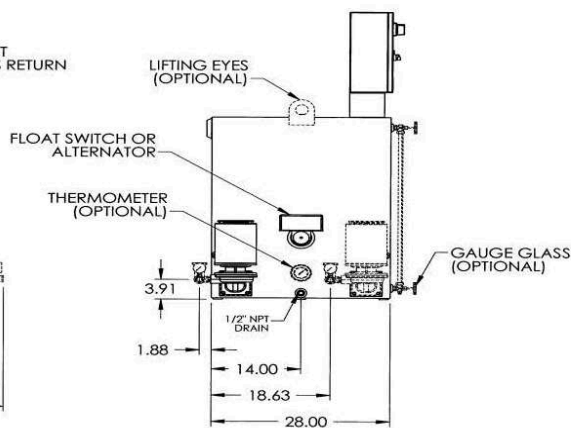
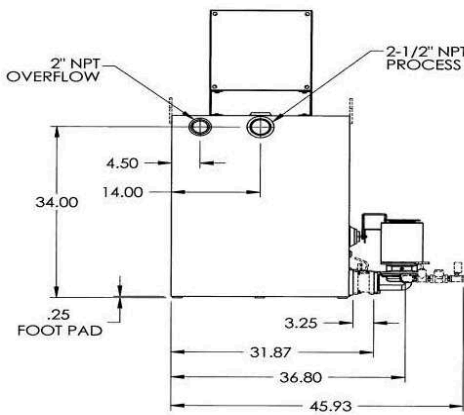
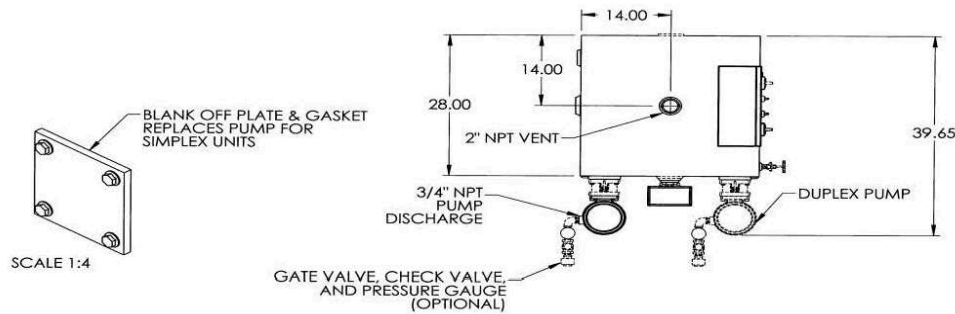

SPECIFY WITH CONFIDENCE, SPECIFY PENN PUMP SYSTEMS